

Straight grab rail made from stainless steel and a rounded chromed ABS brackets which have screw concealment covers. The narrow gap between wall and rail prevents hands from slipping between the wall and can help prevent injury. The rails come in a range of colours or polished stainless steel.

Code **4CAJAS20** Series

Net weight kg 0,38 Dimensions [WxDxH] mm 80x70x385

In use weight capacity Vertical kg 150 Horizontal Kg 150

Use and installation info

Use Wall installation

Cleaning

clean with water and neutral products solvent-free and non-abrasive

Fasteners

Included with the product

Packaging information

Type of package Nylon bag in cardboard packaging

Dimensions [WxDxH] mm 110x75x540 Weight kg 0,62



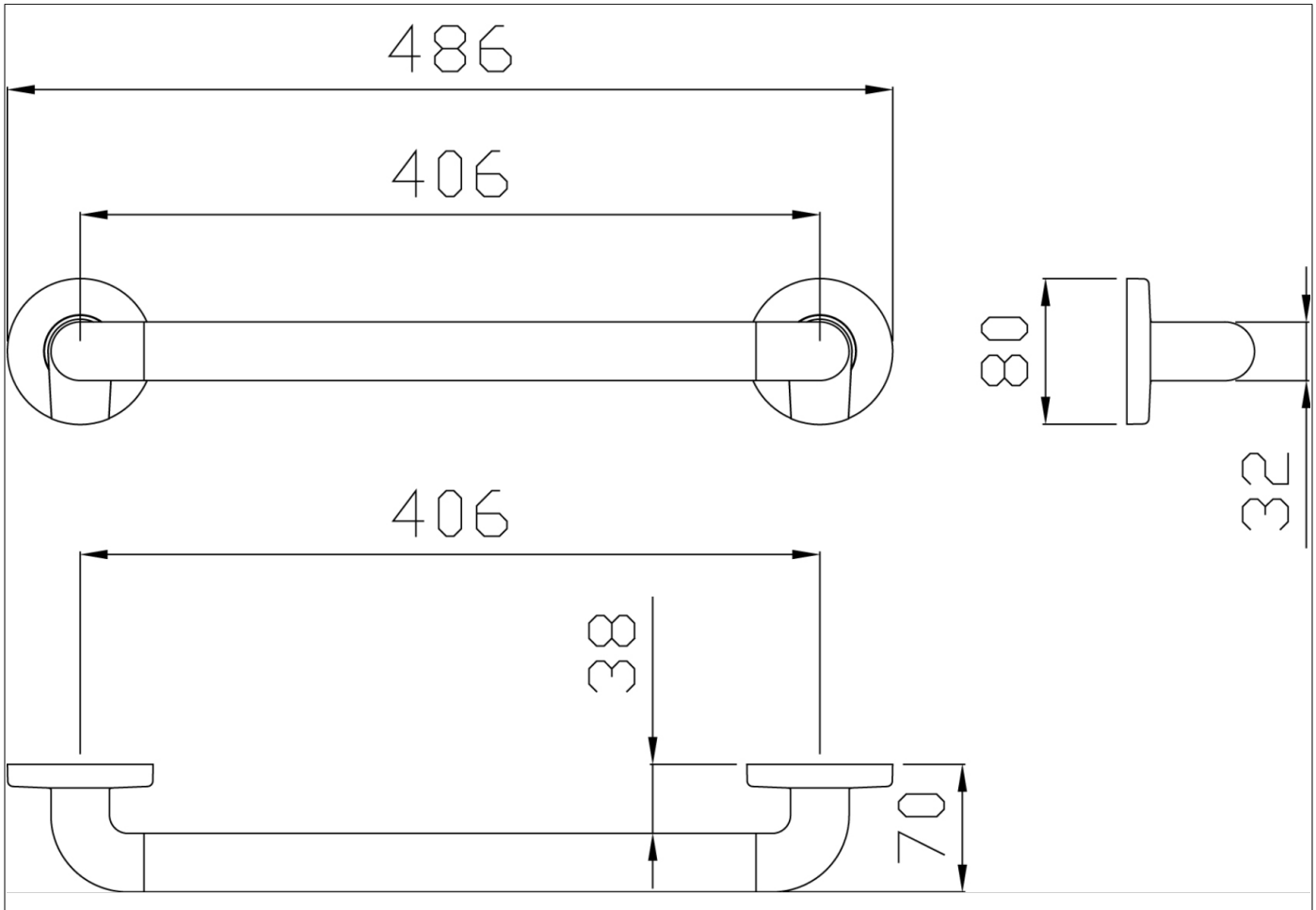

Straight grab rail made from stainless steel and a rounded chromed ABS brackets which have screw concealment covers. The narrow gap between wall and rail prevents hands from slipping between the wall and can help prevent injury. The rails come in a range of colours or polished stainless steel.

Code **4CAJAS21** Series

Net weight kg 0,487 Dimensions [WxDxH] mm 486x70x80

In use weight capacity Vertical kg 150 Horizontal Kg 150

Use and installation info

Use Wall installation

Cleaning

clean with water and neutral products solvent-free and non-abrasive

Fasteners

Included with the product

Packaging information

Type of package Nylon bag in cardboard packaging

Dimensions [WxDxH] mm 110x75x540 Weight kg 0,727



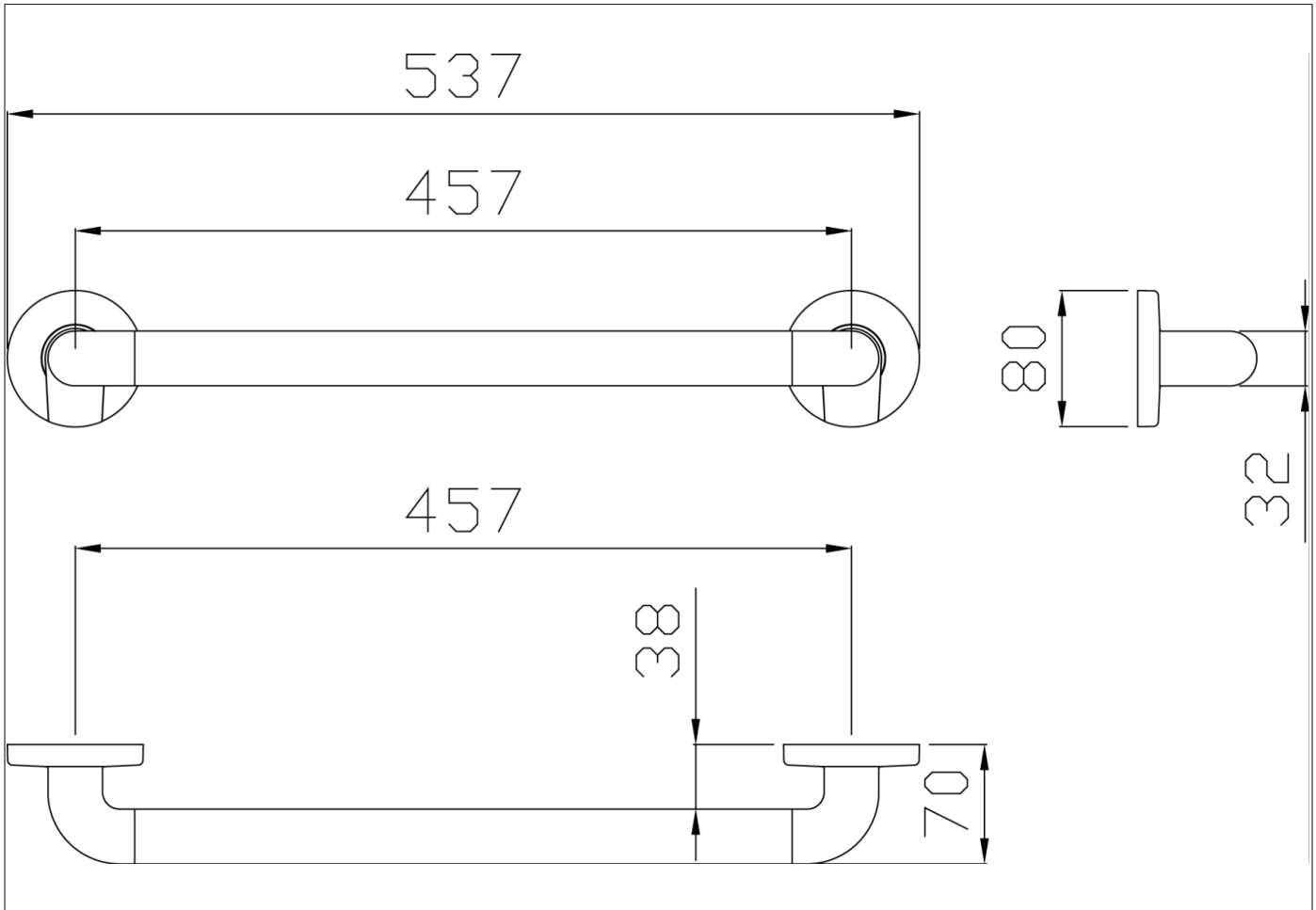

Straight grab rail made from stainless steel and a rounded chromed ABS brackets which have screw concealment covers. The narrow gap between wall and rail prevents hands from slipping between the wall and can help prevent injury. The rails come in a range of colours or polished stainless steel.

Code **4CAJAS22** Series

Net weight kg 0,542 Dimensions [WxDxH] mm 80x70x537

In use weight capacity Vertical kg 150 Horizontal Kg 150

Use and installation info

Use Wall installation

Cleaning

clean with water and neutral products solvent-free and non-abrasive

Fasteners

Included with the product

Packaging information

Type of package Nylon bag in cardboard packaging

Dimensions [WxDxH] mm 110x75x745 Weight kg 0,84



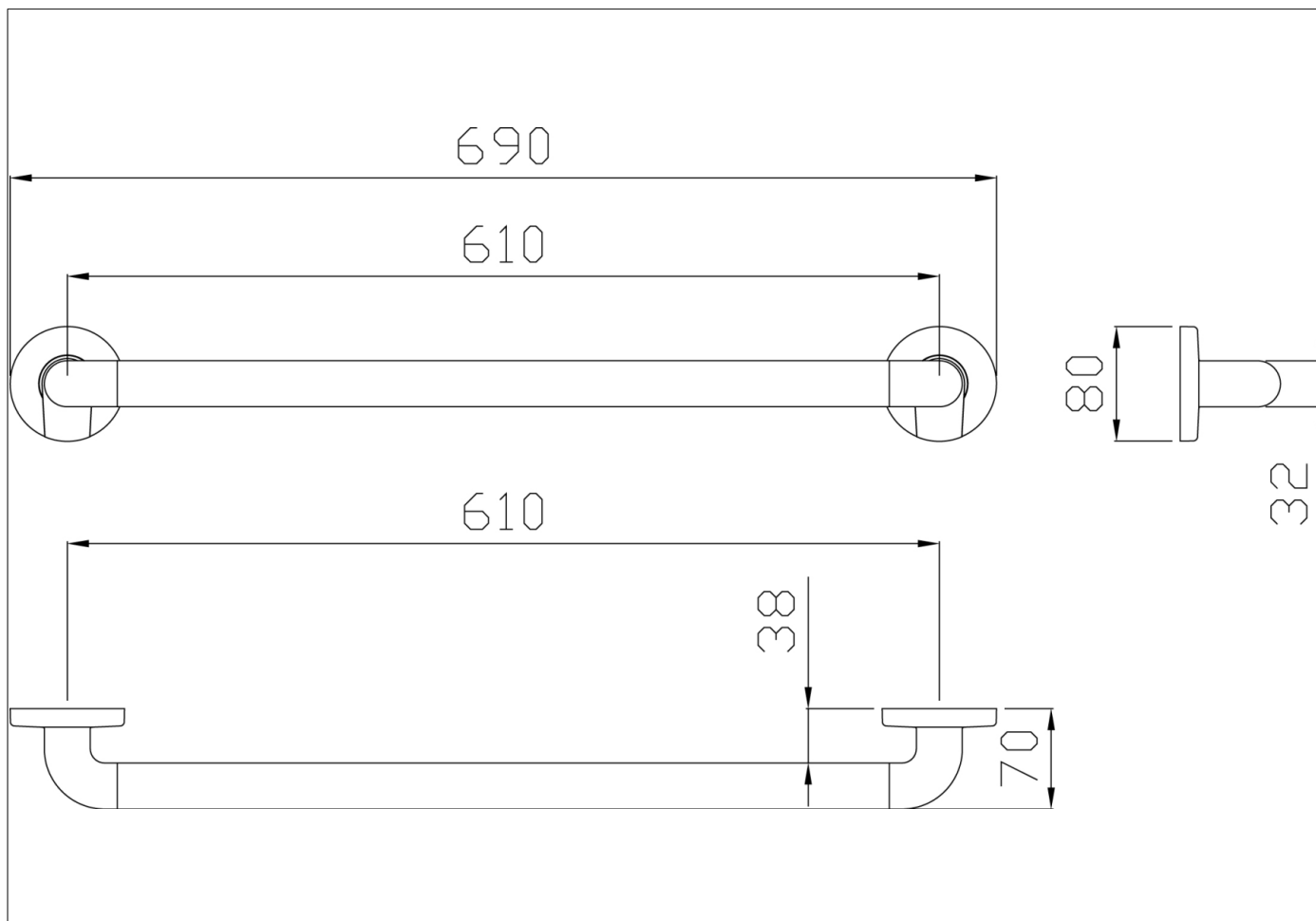

Straight grab rail made from stainless steel and a rounded chromed ABS brackets which have screw concealment covers. The narrow gap between wall and rail prevents hands from slipping between the wall and can help prevent injury. The rails come in a range of colours or polished stainless steel.

Code **4CAJAS23** Series

Net weight kg 0,705 Dimensions [WxDxH] mm 690x70x80

In use weight capacity Vertical kg 150 Horizontal Kg 150

Use and installation info

Use Wall installation

Cleaning

clean with water and neutral products solvent-free and non-abrasive

Fasteners

Included with the product

Packaging information

Type of package Nylon bag in cardboard packaging

Dimensions [WxDxH] mm 110x75x745 Weight kg 1



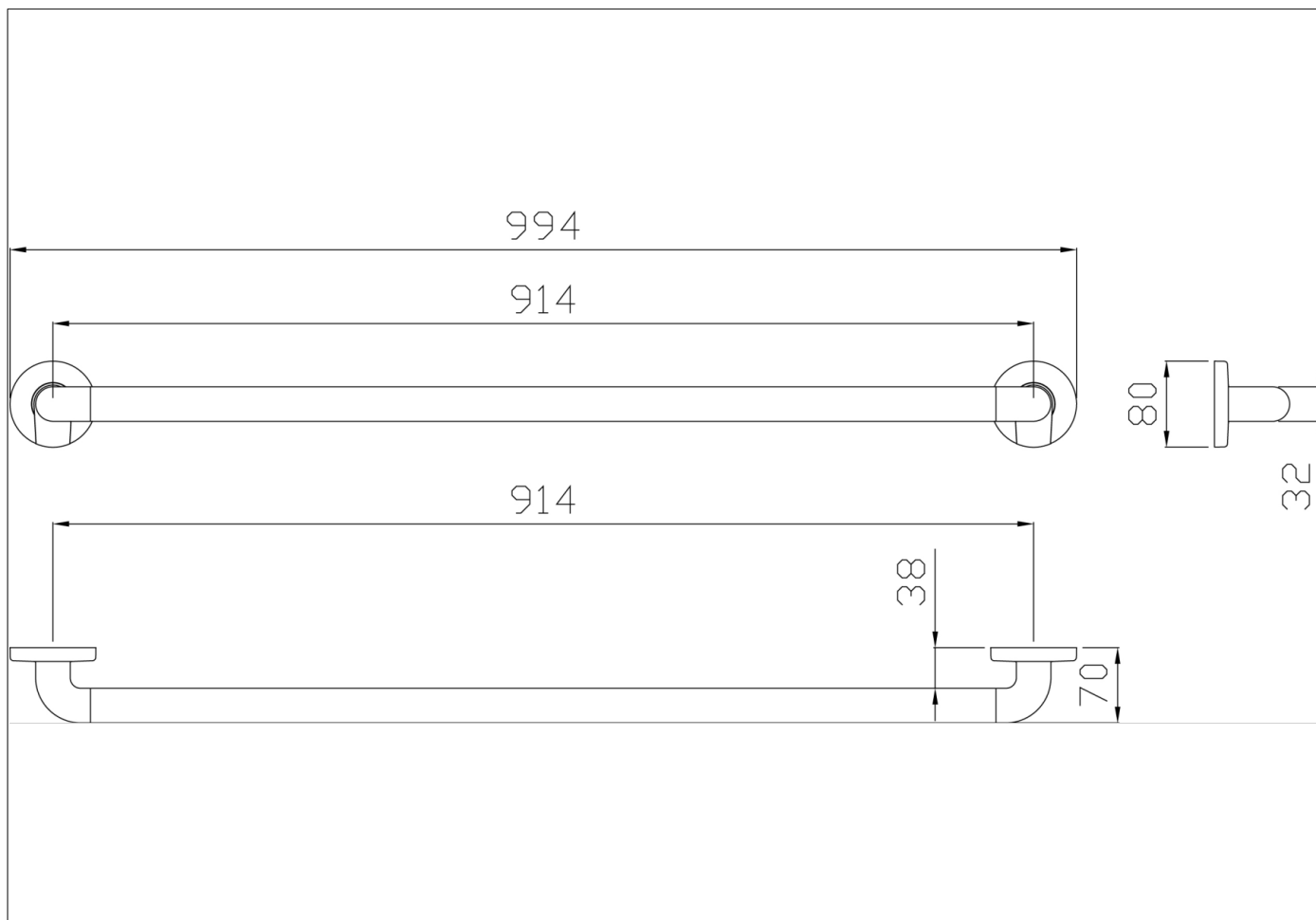

Straight grab rail made from stainless steel and a rounded chromed ABS brackets which have screw concealment covers. The narrow gap between wall and rail prevents hands from slipping between the wall and can help prevent injury. The rails come in a range of colours or polished stainless steel.

Code **4CAJAS24** Series

Net weight kg 1,03 Dimensions [WxDxH] mm 80x70x994

In use weight capacity Vertical kg 150 Horizontal Kg 150

Use and installation info

Use Wall installation

Cleaning

clean with water and neutral products solvent-free and non-abrasive

Fasteners

Included with the product

Packaging information

Type of package Nylon bag in cardboard packaging

Dimensions [WxDxH] mm 110x75x1045 Weight kg 1,425

