



Basin mixer 9000E Tronic

FM Mattsson 9000E Tronic is a new generation of sensor operated mixers in Sweden. All technical parts are integrated in the mixer body for easy maintenance. The temperature is easily set by means of a lever at the side of the mixer. The lever can be fixed in order to secure the mixer against scalding or alternatively remove the lever if you need only a fixed temperature. There is also a programmable function for hygienic flush that prevents the water to be stagnant too long and thereby prevents bacteria to grow.

Article number: 16410000

Unique characteristics



Backflow protection unit type 

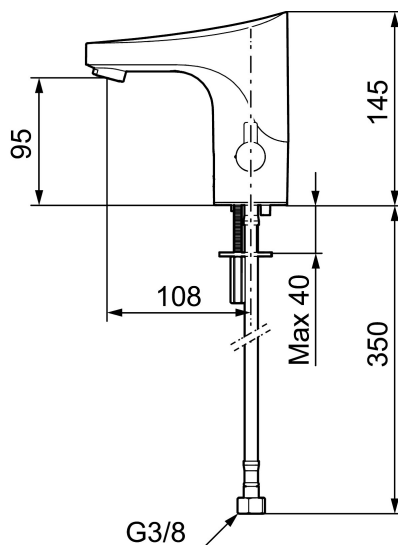

- With temperature knob, battery operation (included battery)
- Soft closing solenoid valve
- Safe against vandalism, complete in metal
- Eco (energy and water saving constant flow aerator, 5 l/min at 200–600 kPa)
- Flush Timeout - safety shut-off to prevent flooding
- 30 sec. rinse time via sensor
- Can be turned off for 60 sec. (eg for cleaning)
- Low power consumption - Long life
- Equipped with system for thermal disinfection against legionella
- IP class sensor, IP67
- Approved non-return valves, EN-Standard EN1717
- Environmental friendly material, Lead free, Nickel Free

Installation:

- Automatic sensor calibration
- After adjusting to the desired temperature, knob can be replaced with a lid
- All models can be adapted for either battery 6V or mains operation 12V AC/DC
- Mains operation requires installation of the AC adapter FMM 1623-0000, and power supply FMM 1619-4000 alternatively transformer FMM 1619-3000
- Soft PEX® hoses with integrated non return valves and filters (stainless steel braided)

- Hole diameter Ø33,5-37 mm

Settings:

- Adjustable max temperature
- Programmable function for hygiene flushing
- Adjustable flush time