



## Shower mixer 9000E

An optimal fusion of design and function. The FM Mattsson 9000E range ushers in a new generation of mixers that are environmentally engineered down to the last detail. The mixer brings beauty and technical perfection. Even in its basic version, the mixer has unique functions that save energy without compromising on comfort.

**Article number:** 81800000

### Unique characteristics

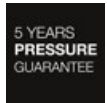

- EcoSafe® mixer
- With shower connection down
- Soft closing with ceramic cartridge
- Approved non-return valve in the shower outlet, EN-Standard EN1717

Backflow protection unit type 

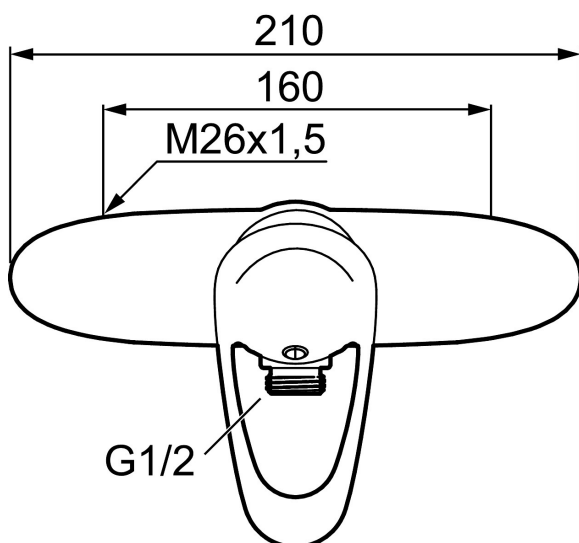

## PRODUCT DESCRIPTION

### Shower mixer 9000E

An optimal fusion of design and function. The FM Mattsson 9000E range ushers in a new generation of mixers that are environmentally engineered down to the last detail. The mixer brings beauty and technical perfection. Even in its basic version, the mixer has unique functions that save energy without compromising on comfort.

**Article number:** 81800000

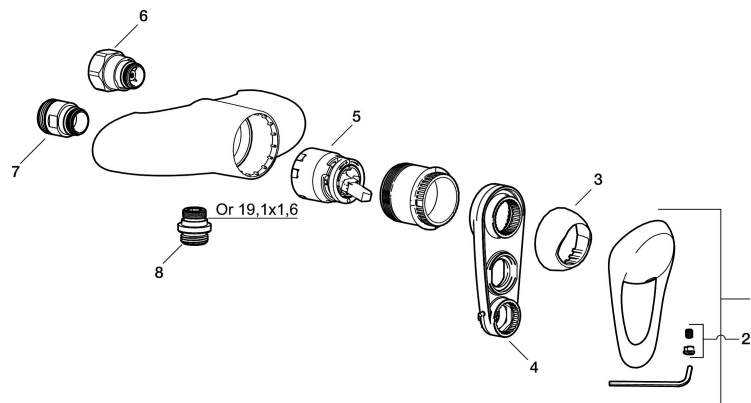

## Sparepartlist

NO.	FMM NO.	RSK	DESCRIPTION
1	58500000	8591936	Lever, complete, L=90 mm
2	58510000	8591944	Cover lid with colour marking
3	58520000	8591945	Cover sleeve
4	60770000	8591918	Service tool
5	59130009	8591972	Ceramic cartridge with tools, carton
6	59810800	8592006	Inlet connectors 150 c/c (left-handed thread)
7	59800800	8592005	Inlet connectors, 160 c/c
8	39710800	8591967	Nipple M18x1-G1/2 for shower mixer