



Bath mixer 9000E II

Safety mixer for bath in a new design. The stylish shape of the mixer supplements the unique functions and the environmental friendly aspect distinguishing the 9000E series. A cleverly engineered technique saves water and energy without compromising on comfort . Centred outlet.

Article number: 82002500

Unique characteristics

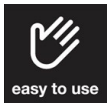
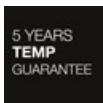

- EcoSafe® mixer
- Pressure balanced thermostatic mixer
- Swivel spout with built-in diverter
- With ceramic sealed headwork
- Temperature handle with safety stop at 38°C
- With Eco-function
- Approved non-return valves, EN-Standard EN1717

Backflow protection unit type  EB

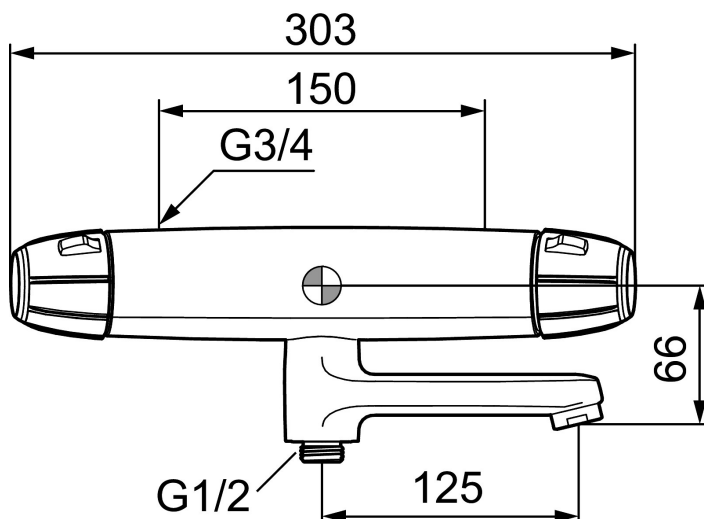

PRODUCT DESCRIPTION

Bath mixer 9000E II

Safety mixer for bath in a new design. The stylish shape of the mixer supplements the unique functions and the environmental friendly aspect distinguishing the 9000E series. A cleverly engineered technique saves water and energy without compromising on comfort . Centred outlet.

Article number: 82002500

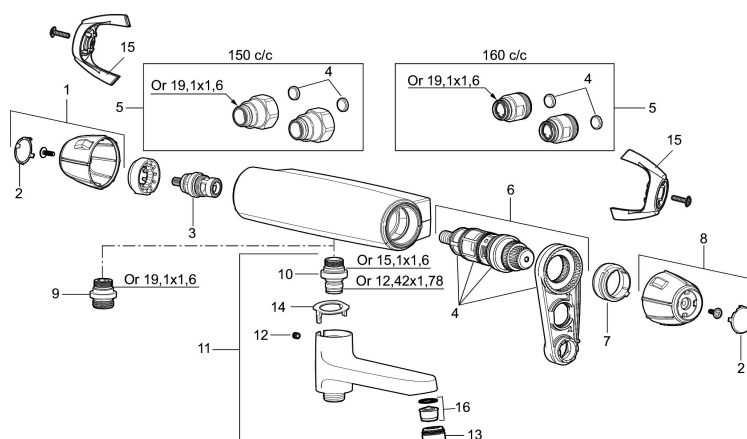

Sparepartlist

NO.	FMM NO.	RSK	DESCRIPTION
1	35782009	8592061	On/off handle, complete
2	39031006	8592062	Cover, black, 2 pcs
3	35900800	8585849	Ceramic on/off headwork
4	38680009	8591701	Filter kit incl. o-rings and service tool
5	59810800	8592006	Inlet connectors 150 c/c (left-handed thread)
5	59800800	8592005	Inlet connectors, 160 c/c
6	38601009	8591609	Thermostatic cartridge, complete, incl. service tool
7	38520007	8591592	Scalding protection ring, standard (black)
7	38520005		Scalding protection ring, max 38 °C, white
8	35782109	8592063	Temperature handle, complete
8	35780150		Temperature handle, complete, max 38 °C
9	39710800	8591967	Nipple M18x1-G1/2 for shower mixer
10	39754000	8591969	Nipple M18x1 with o-ring for bath mixer
11	82990000	8154073	Swivel spout with integrated diverter
12	38086000	8439701	Locking screw
13	29142400	8281526	Housing M24 ext., 13 mm
14	38521000	8295345	Stop ring

NO.	FMM NO.	RSK	DESCRIPTION
15	35970150	8592055	Care-handle, black, 2 pcs
16	29102650	8281547	Aerator insert, 20–24 l/min at 300 kPa